

PUSH BUTTON IN HEAD THERMISTOR TEMPERATURE TRANSMITTER

1.0 DESCRIPTION

The SEM203TH transmitter connects to a thermistor sensor and produces a 4-20 mA signal that is linear with temperature. It is suitable for in head mounting or DIN rail with the addition of RMK-2 clips.

An LED provides a visual indication of sensor fault and programming mode. The transmitter is simply ranged and calibrated on the bench by using a single on-board push button switch, without the need for soldering links. Digital technology ensures accurate and drift free linearization to common curves.

2.0 SPECIFICATION @ 68°F

2.1 Input

Input Types Available	2252Ω - SEM203TH-1 10KΩ - SEM203TH - 2 common thermistor resistance curve having a ration of 9.07 between 0-50°C
Max Excitation Current	2252Ω 240μA 10kΩ 100μA
Range	-13 to 257°F
Minimum Span	10°F
Burnout	Upscale 22 mA (Downscale preset current to order)
Sensor Lead Length	<18' to 710' to maintain CE compliance
Sample Rate	500mS per Reading
Accuracy	±0.25°F within 32 to 212°F ±0.35°F within -13 to 257°F
Thermal Drift	Zero ±0.01°F/°F Span 50 ppm
Connections	Screw Terminals

2.2 Output

Output	4 to 20 mA, 2 wire loop powered
Maximum Output Range	3.8 to 22 mA
Operating Voltage	8 to 30V DC
Accuracy	± 5μA
Thermal Drift	± 1μA/°F
Response Time	500mS to reach 70% of final value
Loop Resistance	800R @ 24V DC
Loop Sensitivity	0.4μA/volt
Loop Noise	±0.001μA
Protection	Reverse Polarity Protected
Connectors	Screw Terminals
Input/Output Isolation	Not Isolated
Warm-up Time	2 Minutes to full accuracy
EMC	Emissions BS EN61326 Susceptibility BS EN61326
Ambient Temp. Range	-4 to 176°F
Ambient Storage	-40 to 176°F
Ambient Humidity	0 to 95% (Non condensing)
Dimension	1.9" [43mm] Diameter - 0.83" [21mm] Height
Weight	25 grams
Default Range	0-100°C. Contact sales office for factory configuration to any other range.



3.0 INSTALLATION

3.1 Mechanical

This transmitter has been specifically designed to be mounted inside a DIN Standard probe head enclosure, which must provide adequate protection from moisture, corrosive atmosphere etc. All cable entries should be sealed using the correct size cable gland. Care must be taken when locating the transmitter to ensure the ambient temperature will remain inside the specified range of -32°F to 158°F. The diagrams show the mechanical layout and a typical application of the transmitter mounted inside a probe head enclosure, with sensor wires entering through the center hole.

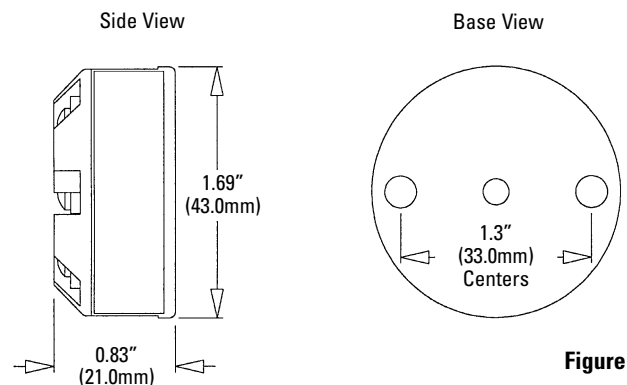

Figure 1

Mounting holes: 2 holes 0.22" (5.5mm) diameter, 1.3" (33mm) centers
Center sensor wire entry: 0.16" (4.0mm) diameter

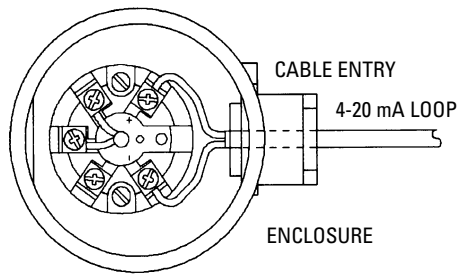

Figure 2

3.1 Electrical

Connections to the transmitter are made to the screw terminals provided on the top face. To maintain CE compliance, input wires must be less than 10 ft. in length and output wiring must be shielded cable grounded at one end only. A hole is provided through the center of the transmitter to allow sensor wires, (entering direct from the probe assembly via a base entry) to be threaded through the transmitter body, direct to the input screw terminals. The screw terminals have been designed to allow all connection wires to enter from either an inner or outer direction.

The transmitter is protected against reverse connection, therefore incorrect connection of the output wires will result in near zero current flow in the loop. Incorrect connection of the sensor wires will result in the transmitter output going to burnout condition.

Figure 3 shows the method of connection to provide a 4-20 mA current loop output. The thermistor sensor shown would normally take the form of a probe assembly with a two wire output. The output loop shows a 24V DC power supply, used to provide loop excitation, the transmitter, and a load, all connected in series. The load symbol represents other equipment in the loop e.g. indicators, controllers, loggers etc.

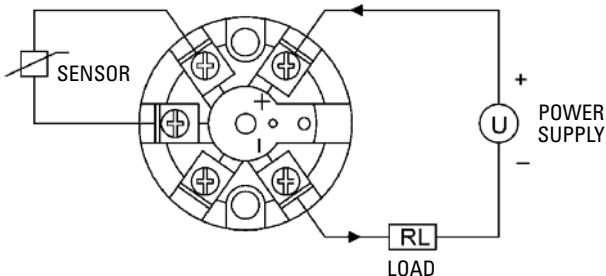

Figure 3

Burnout

Due to the sensing method, certain combinations of open circuit sensor wires may result in the output current dropping for approximately 500mS, before rising to upscale output.

Care must be taken when designing the 4-20 mA circuit to ensure that the total burden of the loop, that is the total voltage requirements of all the equipment in the loop added together, does not exceed the power supply voltage. If a number of devices are connected in the loop, ensure that only one instrument is tied to ground. Grounding the loop at two points will result in shorting out part of the loop and therefore any transmitters in that part of the loop will not operate.

Maximum load resistor, RL, is calculated as follows:

$$RL = (v-8)/20 \times 1000$$

For 24V supply:

$$RL = (24-8)/20 \times 1000 = 800R$$

3.3 EMC

This transmitter conforms with EC directives BS EN61326 when correctly installed in a termination head providing at least IP20 protection and fitted with a sensor with less than 10' of cable.

4.0 RANGES

This transmitter is normally supplied ranged 0 to 100°C, unless a special range has been requested at the time of order. With the aid of suitable equipment, this transmitter can be programmed to a different range by following the simple procedure listed below.

4.1 Equipment

The following apparatus will be required in order to re-range the transmitter:

- Power supply voltage between 10-30V DC, 30 mA min current
- Precision resistance box
- Connecting cables
- 3 mm Diameter screw driver or similar device
- Current meter 0 - 20 mA to monitor loop current
- Thermistor Tables

4.2 Method (See Figure 4)

Refer to Figure 2 and 3 for correct connection and type setting details, this information is duplicated on the transmitter side label.

1. Connect circuit as shown in Figure 4 and set the Resistance Box for temperature required at 4 mA.
2. Press and hold the programming switch by inserting a 3mm diameter screw driver blade through the programming hole, located in the top face of the transmitter housing. Hold the switch for approximately 5 seconds, until the RED programming led flashes. Release the switch.
3. Set the Resistance Box for the required temperature at 20 mA. Allow 10 seconds settling time, then press and release the programming switch. The programming LED will flash quickly for a few moments, then go out. The transmitter is now ranged.
4. Check that the transmitter output range is correct by setting the Resistance Box to the 4 mA and then 20 mA settings, checking the output current reading on the meter.

4.3 Calibration Circuit

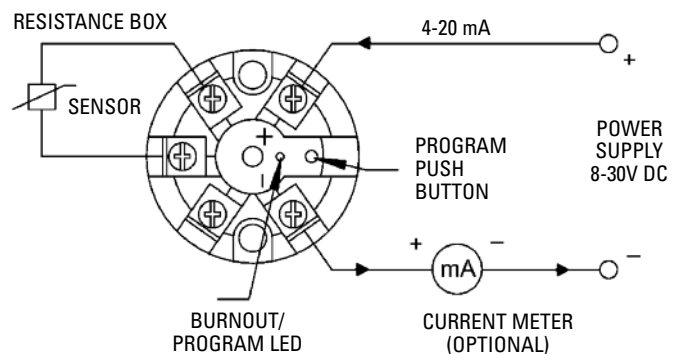

Figure 4

Every effort has been taken to ensure the accuracy of this specification, however we do not accept responsibility for damage, injury, loss or expense resulting from errors and omissions, and we reserve the right of amendment without notice.



PO Box 548, 456 Park Ave.,
Scotch Plains, NJ 07076
P: (908) 490-0232 P: (800) 700-3272
F: (800) 700-5468 E: bm@statinst.com