

ISOLATOR

1.0 DESCRIPTION

The SEM1010 is designed to provide an isolation barrier between a field mounted 4-20 mA transmitter and the process monitoring system. The isolator output is a two wire 4-20 mA current sink. The SEM1010 derives its power from the output loop.

2.0 SPECIFICATION @ 20°C

2.1 SEM1010

INPUT

TYPE	Two wire 4-20 mA Powers & monitors two wire Transmitter from the loop output
RANGE	4-20 MA (25 MAX)
PROTECTION	Current limited
Tx SUPPLY	5 - 15 V Max
MAX LOOP VOLTS	35 Volts

OUTPUT

TYPE	4-20 mA Current Sink Reverse protected
LOOP DROP	5V @ 20 mA (with a 10V Tx drop) 6.5V max @ 20 mA 10V max @ 4 mA

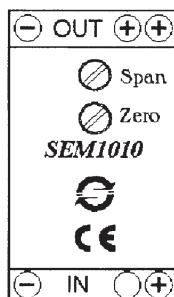
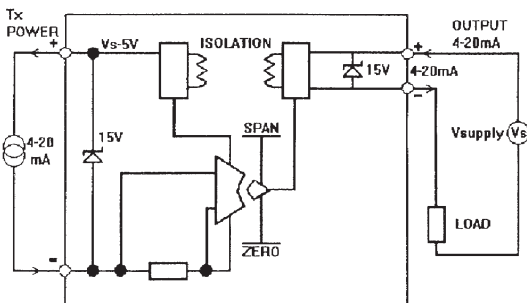

2.2 General Specifications

ISOLATION	500V AC (flash tested @ 1 kV)
ENVIRONMENT	BS EN61010-1 POLLUTION DEGREE 2; INSTALLATION CAT II; CLASS I
AMBIENT	0 - 70°C; 10-95% RH non condensing
LINEARITY	0.05%
STABILITY	100 PPM/°C
RESPONSE TIME	Less than 100mS to reach 70% of final value.
EMC Tested to	IEC 801-2 Susceptibility to E.S.D. IEC 801-3 Radiated Susceptibility IEC 802-4 Susceptibility to conducted interference EN 55022 Radiated Emissions
CONNECTION	Captive clamp screws
CABLE SIZE	Maximum 4mm sq. solid/2.5mm sq stranded
CASE MATERIAL	Grey Polyamide
FLAMMABILITY	To UL94-V0 VDE 0304 Part 3, Level IIIA
DIMENSIONS	60 x 60 x 21mm (67.5 above rail)
MOUNTING	Snap on "top hat" rail (DIN EN50022-35)
ADJUSTMENT	Front Entry Fine Zero and Span Adjustment

3.0 INSTALLATION

3.1 Mechanical

This isolator is designed to be housed within a suitable enclosure that will provide protection from the external environment, and ensure the stated temperature and humidity ranges are not exceeded. The isolator case is designed to snap fit onto a standard "top hat" DIN rail. The isolator may be removed if required by applying pressure with one hand to the bottom face of the enclosure, in a direction parallel with the DIN rail and at the same time gripping the top of the isolator and pulling away from the rail. The isolator may be mounted in any orientation and stacked side by side along the rail.

3.2 Electrical

Connections to the isolator are made via screw terminals. Pressure plates are provided inside each terminal. No special cable type is required for 4-20 mA loops, but for long runs, twisted pair or screened cables are recommended. Screened cables must be used for the input connections. It is also good practice to ensure that the 4-20 mA loop is grounded at one point. Before installation, care must be taken to ensure enough voltage will be provided by the output loop power supply to drive the total loop burden. Refer to the SEM1000 series data sheet for further information on applications of this series of isolators. Please note the isolation provided by this device is not suitable for providing isolation from hazardous voltages, such as mains supplies.

Additional + terminal is provided on output side to allow wiring to be chain connected to a number of units.

4.0 OPERATION

This isolator requires no user adjustment during commissioning, apart from an initial test, to ensure it operates correctly over its full working range. Minor adjustments can be made to the calibration of the device by means of the two front panel accessible calibration potentiometers. Incorrect connection in the loop will not damage the device as long as the specified maximum currents/voltages are not exceeded. If the isolator fails to operate, check loop for bad connections. Ensure enough voltage is available in the loop to power the isolator. In the unlikely event of the isolator not working, it should be returned to the supplier for repair or replacement.

5.0 CALIBRATION

- 5.1 Connect a precision current sink to the input, and a precision current meter in series with the output loop. Power the output with a 24V supply.
- 5.2 Set current sink to 4.000 mA \pm 0.001 mA and adjust the zero potentiometer for 4.000 mA \pm 0.001 mA output.
- 5.3 Set current sink to 20.000 mA \pm 0.001 mA and adjust the span potentiometer for 20.000 mA \pm 0.001 mA output. Repeat steps 5.2 and 5.3 until both points are in calibration.

6.0 MECHANICAL DETAIL

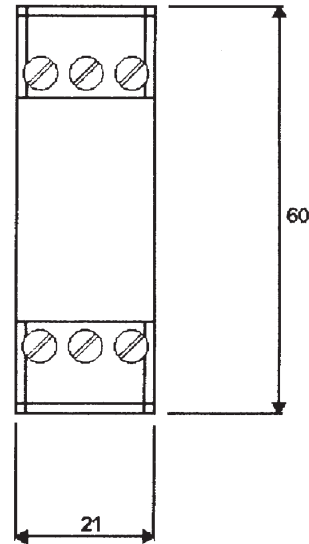
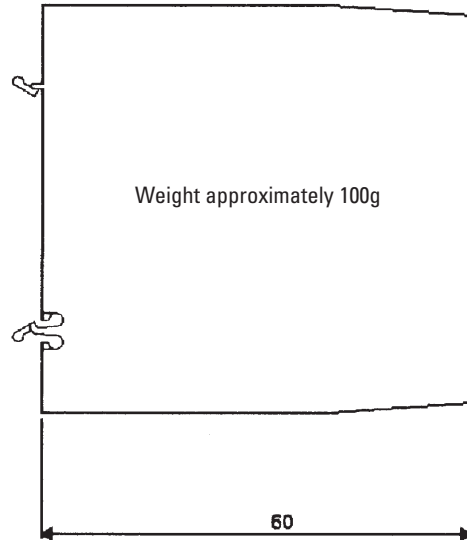

Every effort has been taken to ensure the accuracy of this specification, however we do not accept responsibility for damage, injury, loss or expense resulting from errors and omissions, and we reserve the right of amendment without notice.