



# OPERATING SPECIFICATIONS SEM205P

## PROGRAMMABLE RTD IN HEAD TEMPERATURE TRANSMITTER

### 1.0 DESCRIPTION

The transmitter is a second generation "Smart" in head RTD temperature transmitter that converts the output to a user specified mA transmission signal. The software package RCPW can be used to program the unit.

### 2.0 SPECIFICATION @ 68°F

#### 2.1 Input

Sensor	PT-100 (2 or 3 wire)
Sensor Range	-200 to +1562°F
Minimum Span <sup>1</sup>	50°F
Linearization	BS EN 60751 (IEC 751) BS 1904 (DIN 43760) JISC 1604 CUSTOM [X] <sup>3</sup>
Basic Measurement Accuracy <sup>2</sup>	±0.01% FRI ±0.05% Rdg (FRI = Full Range Input)
Thermal Drift	Zero 0.008 °F/°F, Span 400 ppm/°F
Excitation Current	< 1 mA Maximum
Maximum Lead Resistance	50 ohms/leg
Lead Resistance Effect	0.004°F/ohm

- Notes:**
1. Any span may be selected, full accuracy is only guaranteed for spans greater than the minimum recommended.
  2. Basic Measurement Accuracy includes the effects of calibration, linearization and repeatability.
  3. Customer linearization requirements are available preprogrammed at the factory. Contact your supplier for details

#### 2.2 Output

Output Range	4-20 mA (>3.8 to <20.2 mA)
Maximum Output	23 mA
Accuracy	±5µA
Voltage Effect	0.2µA/V
Thermal Drift	1µA/°C
Supply Voltage	10 to 35V
Maximum Output Load	[Vsupply - 10/20] K ohms (e.g. 700 ohms @ 24V)

#### 2.2 General

Update Time	250 mS Maximum
Time Constant (Filter Off)	< 1 Second (Time to reach 63% final value)
Filter Factor Programmable	Off, 2 seconds, 10 seconds or Adaptive
Warm-up Time	2 minutes to full accuracy

#### Environmental

Ambient Operating Range	-40 to 185°F
Ambient Storage Temperature	-58 to 212°F
Ambient Humidity Range	10 to 90% RH non condensing

#### Approvals

Emissions	EN50081
Immunity	EN50082



#### Mechanical

Enclosure	DIN standard terminal block size
Material	ABS
Weight	27g
Dimensions	1.69" [43mm] dia. x 0.83" [21mm] height

#### Communications

PC Interface	RS232 via configurator
Minimum Output Load	250 ohms for "In Loop" programming
Maximum Cable Length	1000m
Configurable Parameters	Sensor type: Burnout: °C/°F: Output: Hi/Lo: Filter: Tag: User Offset
Comms Protocol	ANSI X3.28 1976
Data Rate	1200 baud

### 2.4 Intrinsically Safe Applications

#### 2.4.1 Intrinsically Safe Applications

SEM205X	EEx ia IIC T4...T6 KEMA Ex-98.D.1844X
---------	--

Special conditions for safe use: The apparatus must only be connected to intrinsically safe circuits with the following maximum values: Umax - 30V; Imax - 100 mA; Pmax - 750mW

The apparatus must be housed in an enclosure which provides a degree of protection of IP20 for the terminals as per EN60529

#### 2.4.2 FM Applications

Factory Mutual: Intrinsically safe apparatus for CLI, DIV1, GP ABCD T4@85°C; T5@50°C; T6@40°C. For installation and maintenance see control drawing SA4-3429-01.

### 3.0 INSTALLATION

#### 3.1 Mechanical

The transmitter is mounted using two 5,5mm diameter holes, on standard 63 inch centers and will fit a DIN standard termination head. The transmitter should be installed with adequate protection from moisture and corrosive atmospheres.

**SEM205X must be installed as section 2.4. It is the responsibility of the installer to follow the relevant installation/wiring regulations when installing apparatus in hazardous areas.**

Care must be taken when locating the transmitter to ensure the ambient temperature remains within the specified operating range. Figure 1 shows the mechanical layout and a typical application of the transmitter mounted inside a termination head enclosure, with sensor wires entering through the center of the transmitter body.

Figure 1

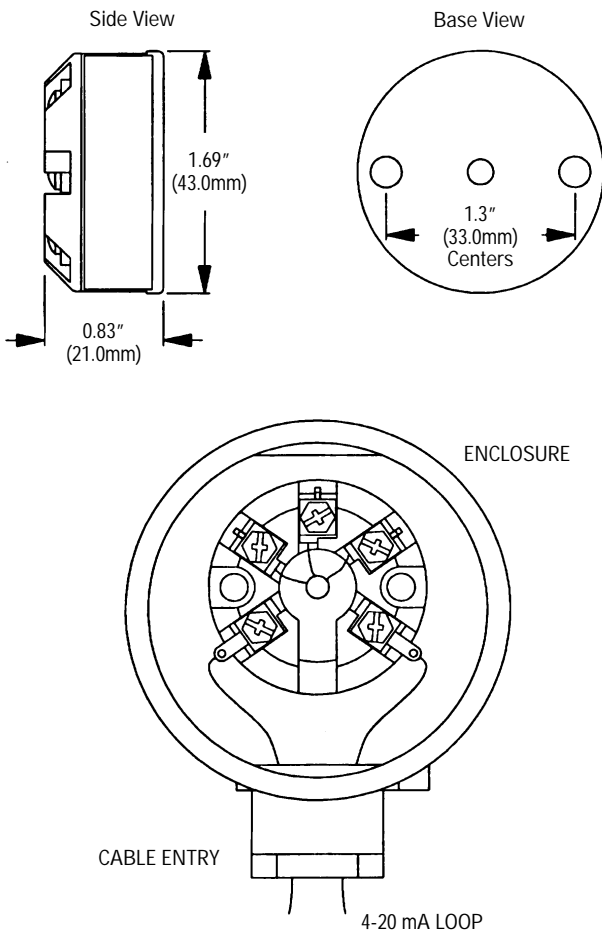

#### 3.2 Electrical

Connections to the transmitter are made to the screw terminals provided on the top face. No special wires are required for the output connections, but shielded twisted pair cable are the most suitable for long runs. It is recommended that shielded cable is used for the three input signal wires for cable runs greater than one meter. All three input wires must have the same core diameter to maintain equal lead resistance in each wire. A Ø4.5mm hole is provided through the center of the transmitter to allow sensor wires to be threaded through the transmitter body direct to the input screw terminals. The screw terminals have been designed to allow all connection wires to enter from an inner or an outer direction.

Figure 2 shows the method of connection to provide a 4-20 mA current loop output. The Pt100 sensor shown would normally take the form of a probe assembly with a three wire connection. The output loop has a voltage power supply used to provide loop excitation. The load symbol represents other equipment in the loop, normally indicators, controllers or loggers. Care must be taken when designing the 4-30 mA circuit to ensure that the total voltage requirements of all the equipment in the loop added together, does not exceed the power supply voltage. If a number of instruments are connected in the loop, ensure that only one instrument is tied to ground. Grounding the loop at two points will cause a short circuit of part of the loop leading to measurement errors.

To guarantee CE compliance, sensor leads must be less than 10 feet long and the transmitter housing should prevent access to the transmitter during normal operation.

Figure 2

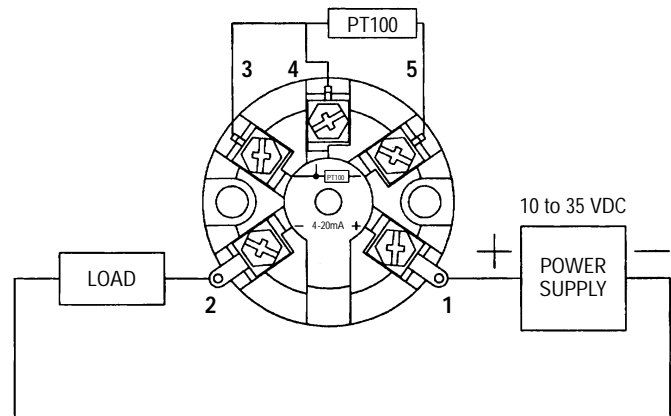

*Every effort has been taken to ensure the accuracy of this specification, however we do not accept responsibility for damage, injury, loss or expense resulting from errors and omissions, and we reserve the right of amendment without notice.*

**STATUS INSTRUMENTS INC.** [www.statinst.com](http://www.statinst.com)

PO Box 548, 456 Park Ave., Scotch Plains, NJ 07076 Ph: (908) 490-0232  
Ph: (800) 700-3272 Fax: (800) 700-5468 Email: rc@statinst.com