

## SEM710 USER GUIDE

HEAD MOUNTED TRANSMITTER  
 UNIVERSAL TEMPERATURE INPUT  
 TWO WIRE (4 to 20) mA OUTPUT WITH  
 DISPLAY

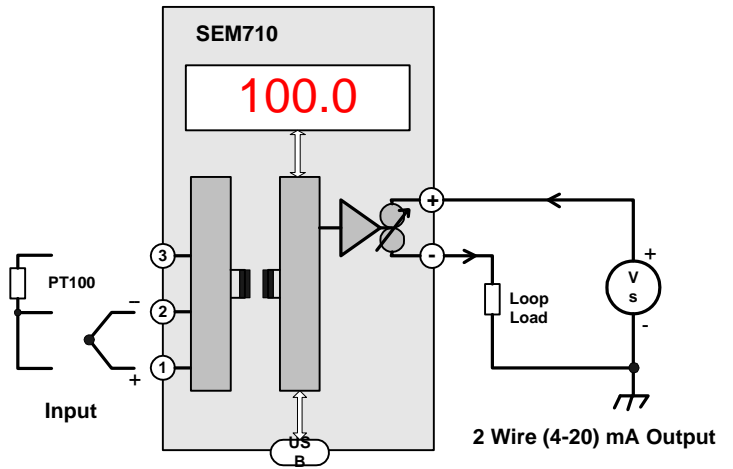

Important - Please read this document before installing.



Every effort has been taken to ensure the accuracy of this document, however we do not accept responsibility for damage, injury, loss or expense resulting from errors and omissions, and we reserve the right of amendment without notice.



### IMPORTANT - CE & SAFETY REQUIREMENTS

Product must be mounted inside a suitable enclosure providing environmental protection to IP65 or greater.

To maintain CE EMC requirements, input wires must be less than 30 meters.

The product contains no serviceable parts, or internal adjustments. No attempt must be made to repair this product. Faulty units must be returned to supplier for repair.

This product must be installed by a qualified person. All electrical wiring must be carried out in accordance with the appropriate regulations for the place of installation.

Before attempting any electrical connection work, please ensure all supplies are switched off.

ABSOLUTE MAXIMUM OPERATING CONDITIONS (To exceed may cause damage to the unit):-

Supply Voltage	± 30 VDC (Protected for over voltage and reverse connection)
Current with over voltage	± 200 mA
Input Voltage	± 5 V between any terminals
Input Current	± 100 mA between terminals 7 & 10
Ambient	Temperature (-30 to 75) °C Humidity (10 to 95) % RH (Non condensing)

### PRODUCT SPECIFICATION

Please refer to the product data sheet for full specification, available to download at [www.statinst.com](http://www.statinst.com).

### RECEIVE AND UNPACKING

Please inspect the packaging and instrument thoroughly for any signs of transit damage. If the instrument has been damaged, please notify your supplier immediately.

### CONFIGURATION



IMPORTANT The SEM710 can be configured while connected and powered, but a portable battery powered computer must be used to avoid the effects of ground loops.

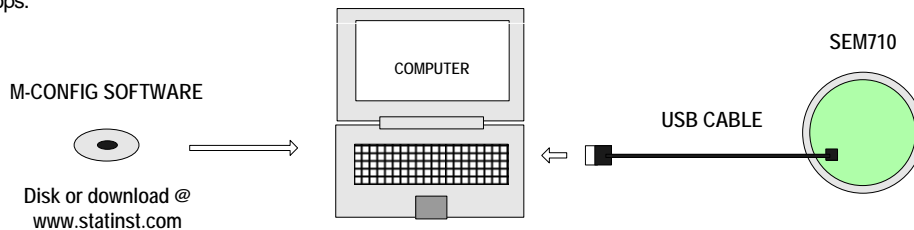

The following parameter can be configured by simply entering as prompted by the software package.

- Input type (K, J, E, N, T, R, S, Pt100)
- Low range
- High range
- Units (°C, °F)
- Burnout (direction of output current on sensor burnout)
- User Trim (ON / OFF) [option to lock out trim function]
- Display mode Input (°C / °F) or Output mA

Factory default:

- Input type = P
- Low Range = 0
- High Range = 100
- Units = °C
- Burnout = UPSCALE
- User Trim = ON
- Display = °C

## MECHANICAL INSTALLATION

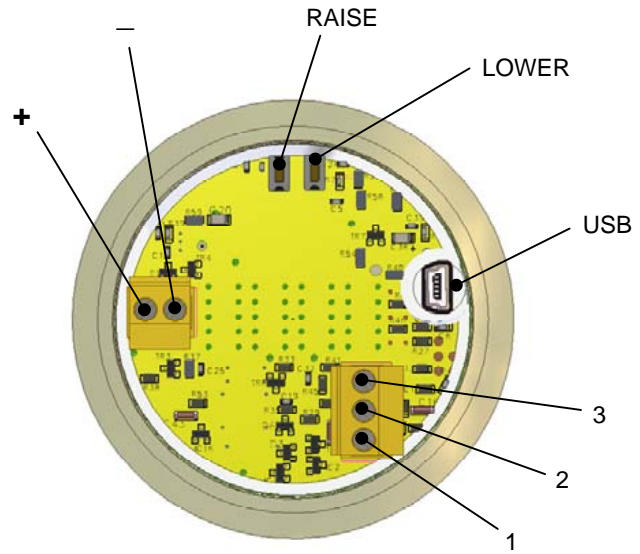
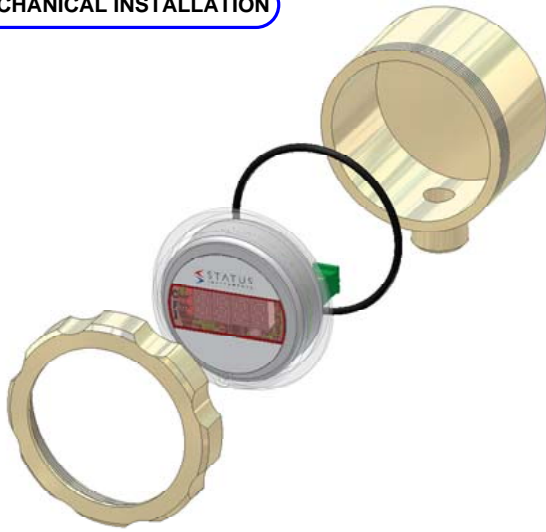

## ELECTRICAL INSTALLATION



TURN OFF SUPPLY BEFORE WORKING ON ANY ELECTRICAL CONNECTION

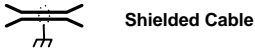

Shielded Cable



Shielded TC Compensation Cable



Twisted Pair

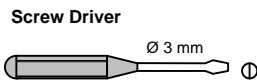

Screw Driver

Ø 3 mm

### INPUT CONNECTION

For cable lengths < 3 Meters shielded or twisted pair is not required.

For cable length > 3 Meters and < 30 Meters shielded or twisted pair is required.

Cable lengths > 30 Meters are not recommended.

Pt 100 Inputs of all three wires must be equal length (resistance).

T/C Inputs must use the correct compensation cable.

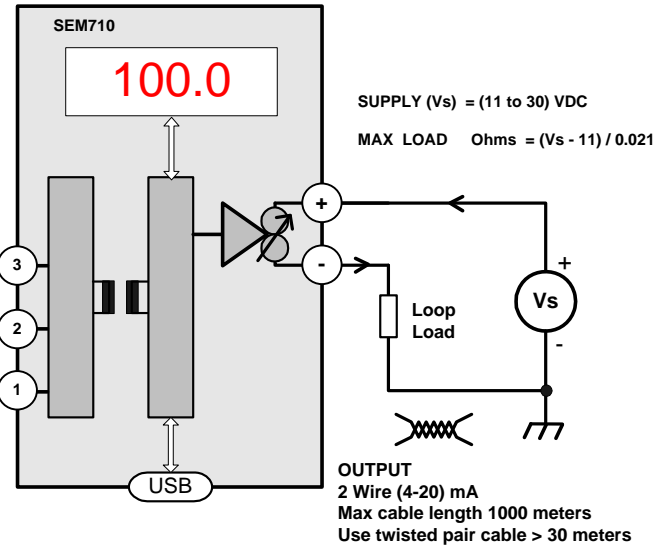
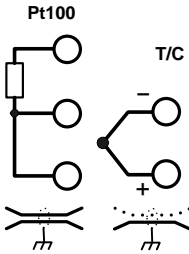

## USER TRIM

### Power Supply (24VDC)

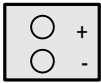

### Input Simulator

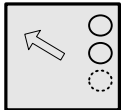

User trim function allows manual adjustment of the output current, this is useful for minor calibration adjustment or trimming out any sensor error, ± 5% of range adjustment is available at both offset and span. Raise and lower buttons are provided on the back, of the transmitter, accessed using a 3 mm flat blade screw driver. Insert the screw driver into the appropriate slot to operate the button. The button has a click action.

The transmitter will automatically detect the correct trim point (offset or span) based on the output current drive. Offset will be trimmed when the current is between (3.8 to 6) mA, span when the current is between (18 to 22) mA. No trim action occurs at any other current.

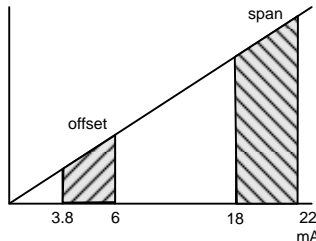

### METHOD

1.0 Ensure the SEM710 is correctly configured. Connect transmitter to a suitable input simulator or sensor. Connect output to a 24V dc supply. Turn supply on, set input to either offset or span calibration point.

2.0 During normal operation the SEM710 Display reading is calculated from the output current drive not directly from the input, therefore the display may be used to monitor trim adjustment. If required the output current may also be monitored with a current meter.

3.0 If the input falls outside the ranged output the SEM710 will enter burnout condition on the output, but will continue to display the temperature. The SEM710 will indicate this by alternating the display to show 'OuER' or 'uND' depending on the burnout direction of the input reading.

4.0 Trim output current by pressing either the raise or lower button, single click to step advance, or press continuously to auto advance. The SEM710 unit will automatically detect the correct trim point.

## DISPLAY

### DISPLAY ERROR MESSAGES

ERR	u Sensor or system error
. (dec. pt.)	u Configuration powered by USB
OuER (over 105.0)	u Output over range (flashes actual I/P measurement then Error Message)
uND (under -0.5)	u Output under range (flashes actual I/P measurement then Error Message)

or Sensor

