

- TWO INDEPENDENT CHANNELS
- PUSH BUTTON CALIBRATION
- RTD SENSOR INPUT
- DRIFT FREE DIGITAL LINEARIZATION
- RE-RANGEABLE WITHOUT A PC
- HIGH DENSITY PACKAGING



DUAL CHANNEL RTD DIN RAIL PUSH BUTTON TEMPERATURE TRANSMITTER SEM523P

INTRODUCTION

The **SEM523P** is a dual channel DIN rail temperature transmitter which accepts common RTD sensors and converts them into a 4-20 mA linear output. Since Zero and Span are set to conform to a particular sensor type, the sensor temperature co-efficient (0.00385, 0.00392 etc.) has little to no effect on accuracy.

The simple push of a button ranges and calibrates the **SEM523P** transmitter. There is no need for jumpers, pot adjustment or a PC.

Ease of re-ranging assures you will have the range you need in stock.

High accuracy, stability, and flexibility at a very attractive price make the **SEM523P** the transmitter of choice for many applications. The **SEM523P** provides a level of performance superior to analog units at a comparable price.

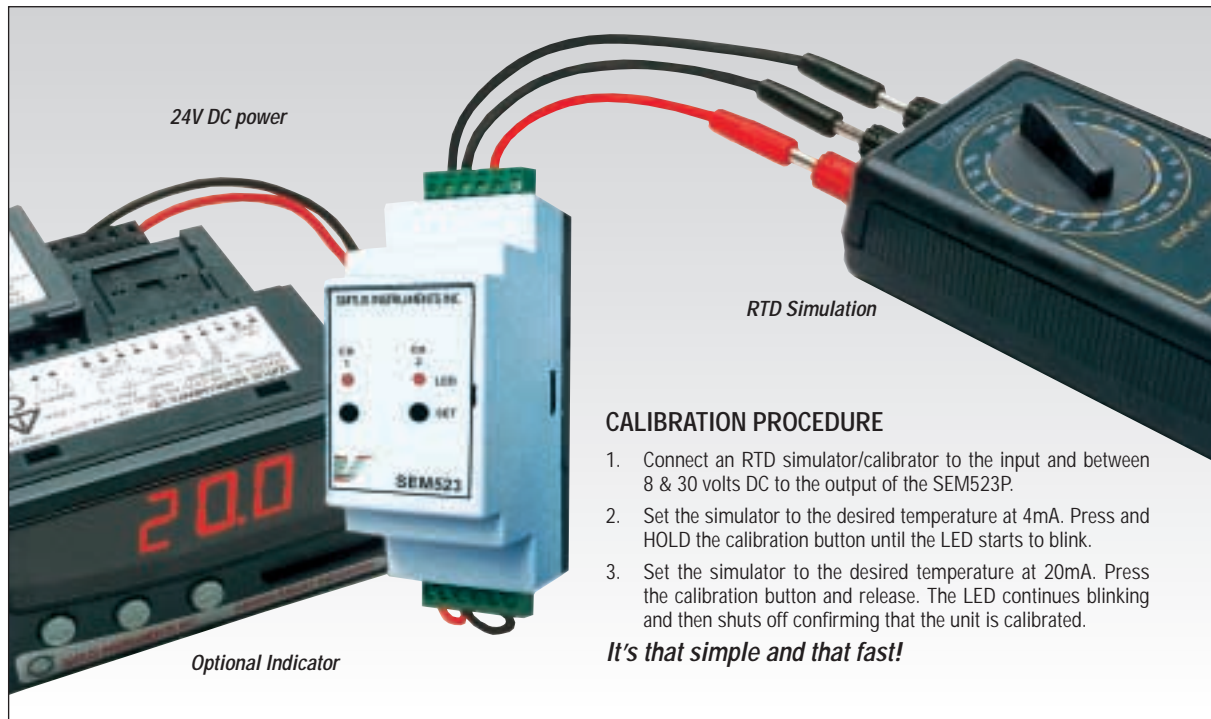

CALIBRATION PROCEDURE

1. Connect an RTD simulator/calibrator to the input and between 8 & 30 volts DC to the output of the SEM523P.
2. Set the simulator to the desired temperature at 4mA. Press and HOLD the calibration button until the LED starts to blink.
3. Set the simulator to the desired temperature at 20mA. Press the calibration button and release. The LED continues blinking and then shuts off confirming that the unit is calibrated.

It's that simple and that fast!



STATUS INSTRUMENTS INC.

PO Box 548, 456 Park Ave., Scotch Plains, NJ 07076
 Phone: (800) 700-3272 Fax: (800) 700-5468 (US & CA only)
 Phone: (908) 490-0232
 Email: rc@statinst.com Internet Address: www.statinst.com



SEM523P 7.02/PDF

SPECIFICATION @ 68°F

INPUT	
Input Type	3 Wire Pt100 sensor (optional 3 wire Pt-500 or Pt-1000)
Range	-328°F to 1562°F
Minimum span	68°F
Lead resistance	
Maximum	100 Ω per leg
Effect	0.072°F/ohm (excluding mismatch)
Sample rate	500 mS
Accuracy	±0.18°F ±0.1% rdg (-148°F to 932°F) ±0.36°F ±0.2% rdg (-328°F to 1562°F)
Thermal drift	
Zero	±0.01°F/°F
Span	50ppm

OUTPUT	
Output range	4-20 mA 2 wire loop powered (Can be ranged 20-4mA) Maximum 3.8 to 22mA
Supply voltage	8 to 30 VDC
Accuracy	±5µA
Burnout	Up-Scale 22mA (Downscale to order)
Thermal drift	
Zero	±0.067µA/°F
Span	±0.16µA/°F
Response time	500mS to reach 70% of Value
Loop resistance	700R at 24VDC
Ripple rejection	±0.002µA/Volt (measured @ 50 Hz 1 volt p-p)

ORDER CODE

MODEL	SENSOR
SEM523P	Dual INPUT PT Sensor -1: 100 Ω RTD -5: 500 Ω RTD -10: 1000 Ω RTD

Note:
All units supplied with Upscale Burnout. Contact sales office for Downscale versions.

GENERAL	
Channels	2 independent
Channel 1 to 2 isolation	500 VDC
Terminals	Two part screw terminal with rising clamp Max cable size 0.059 in. sq 500mS to reach 70% of Value
Warm-up time	2 minutes to full accuracy
EMC conforms to	Emissions BS EN50081-1 Susceptibility BS EN50081-2
Ambient temp range	0 to 70°C
Ambient humidity	0 to 95% (non condensing)
Calibration period	12 months to maintain published specification
Display	Red LED indicates prog. mode/out of range sensor

PHYSICAL	
Enclosure	DIN Rail enclosure conforming to DIN 43 880
Top	Color Grey Material Lexan™ Approval UL94-V0 (self extinguishing)
Base	Color Black Material Noryl Approval UL94-V0 (self extinguishing)

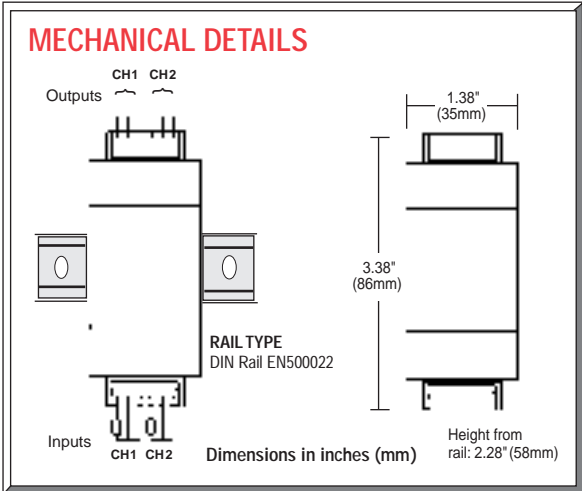

LOCAL REPRESENTATION

Every effort has been taken to ensure the accuracy of this specification, however we do not accept responsibility for damage, injury, loss or expense resulting from errors and omissions, and we reserve the right of amendment without notice.