

USB CONFIGURABLE IN HEAD TEMPERATURE TRANSMITTERS

SEM206 Series

- SIMPLE CONFIGURATION VIA USB PORT
- CONFIGURABLE IN SECONDS
- RTD – PT100 and THERMOCOUPLE VERSIONS
- INPUT/OUTPUT ISOLATION
- OVER RANGE LED INDICATOR
- PROGRAMMABLE BURNOUT
- 10 YEAR WARRANTY



INTRODUCTION

The SEM206P & SEM206TC are cost effective “smart” in head transmitters that accept Pt100 or thermocouple temperature sensor inputs and converts them to an output over a configured range to a standard industrial 4 to 20 mA transmission signal.

PC configuration allows the user to select Pt100 on SEM206P or Thermocouple Type on SEM206TC, Range, Units, and Burnout direction, without requiring calibration equipment. Configuration is performed quickly using our new USB port driven configurator by simply connecting two leads to the SEM206P or SEM206TC loop terminals and following the instructions from our free software. Calibration set up may be saved as a file on the PC for later use.

The SEM206 in head transmitters incorporates the latest digital technology to ensure accurate drift free performance.

If required, the desired range can be specified at the time of order, removing the need for configuration in the field. If the range is not specified then the SEM206P transmitter will be shipped with the default range of 0 to 100°C and the SEM206TC will be shipped with the default range of 0 to 1,000°C for Type “K” thermocouple.

INPUTS

MODEL	INPUT	RANGE	MIN. SPAN	ACCURACY (Note 1)	STABILITY	O/C	CJ (Note 3)	SENSOR EXCITE (Note 4)
SEM206TC	K	-328 to 2498°F	68°F	±0.1% of FSR ±0.9°F	Zero 0.1 °C/°C Span 0.05 °C/°C	Yes	Yes	N/A
	J	-148 to 2192°F						
	E	-148 to 1832°F						
	N	-292 to 2372°F						
	T	-148 to 752°F	392°F	±0.2% of FSR ±0.9°F				
	R	14 to 3200°F		±0.9°F ±0.1% of FSR (Note 2)				
	S	14 to 3200°F		±0.9°F ±1% of FSR (Note 2)				
	mV	-10 to 70mV	1mV	±0.02% of FSR	N/A	N/A		
SEM206P	Pt100 2 or 3 wire	-328 to 1562°F (18 to 390) Ω	50°F	±0.18F/ ±0.05% of R _{dg}	±0.005% of FSR	Yes	N/A	<200µA

Key: R_{dg} = Reading; FSR = Full Scale Range; O/C = Programmable Open Circuit Sensor Detect; CJ = Cold Junction Error

- Notes:**
1. Accuracy for Pt100 and T/C do not include sensor and cold junction errors.
 2. Only over the range 1472 to 2912°F.
 3. Cold junction range: -4 to 158°F, Accuracy: ±0.9°F, Tracking: ±0.09°F.
 4. Pt100 Input Maximum lead resistance: 20R, Lead effect: 0.027°F/Ω

GENERAL

Update Time	500 ms
Response Time	1 second
Start-Up Time	4 seconds (Output < 4mA during stat-up)
Warm-Up Time	1 minute to fill accuracy
Power Supply	10 to 30 VDC
Isolation	Input to output tested at 250VDC (T/C version only)
Ambient	Operating: -40 to 185°F, 10 to 90% RH non condensing. Storage: -58 to 194°F
Approvals	CE tested to BS EN 61326 (Sensor input wires to be < 3 meters to comply)

MECHANICAL

Dimensions	1.68" diameter; 0.83" height
Weight	31 grams (encapsulated)
Terminals	Screw terminals
Cable	2.5 mm maximum
Material	ABS
Flammability	UL94V040

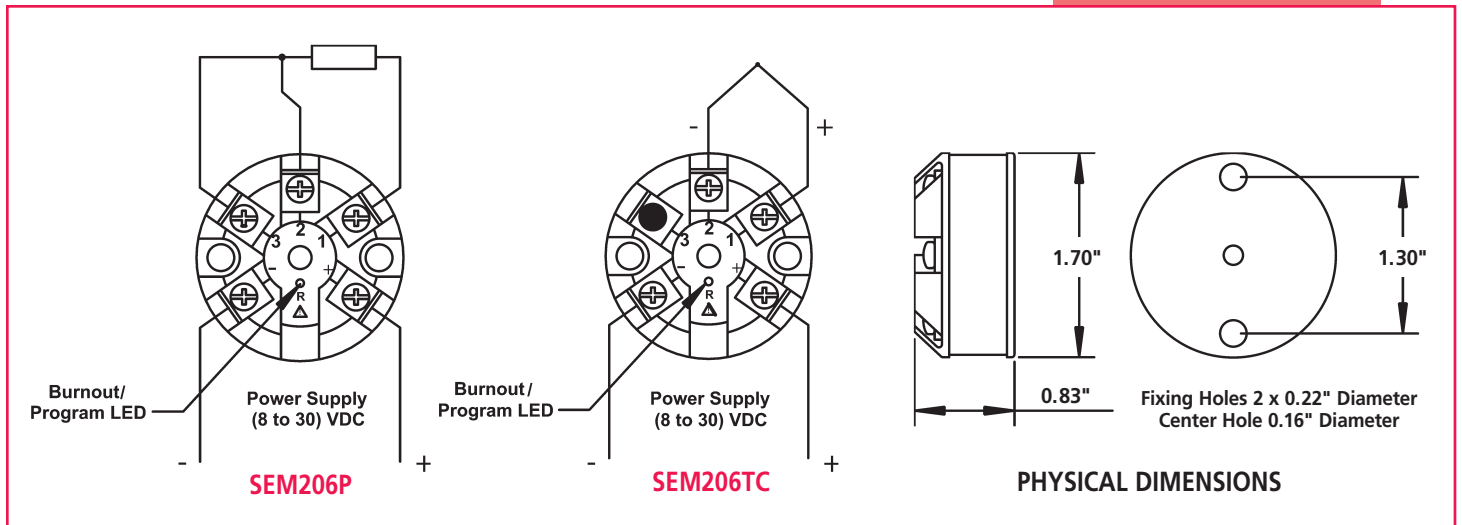

SEM206P and SEM206TC OUTPUT

Type	Two wire current loop; signal range 4 to 20mA; full range 3.8 to 21.5mA
Calibration Accuracy	(mA output / 2000) or $\pm 5\mu\text{A}$ (which ever is greater)
Loop Voltage Effect	$\pm 0.2 \mu\text{A} / \text{V}$
Thermal Drift	$\pm 0.07 \mu\text{A} / ^\circ\text{F}$
Protection	Reverse connection and over-voltage protection.
Maximum Output Load	$[(V_{\text{supply}} - 10) / 20]$ K ohms (Example: 700 ohms @24V)

ORDER CODES:

SEM206P	RTD INPUT / CURRENT OUTPUT
SEM206TC	THERMOCOUPLE INPUT / CURRENT OUTPUT

Accessories

USB KIT	USB CONFIGURATION KIT
M-CONFIG	SOFTWARE (FREE FROM INTERNET SITE)
RMK-2	DIN RAIL ADAPTER CLIP

Associated Products

SEM203P	RTD INPUT / mA OUTPUT (PUSH BUTTON CAL)
SEM203TC	T/C INPUT / mA OUTPUT (PUSH BUTTON CAL)
SEM710	INDICATING TEMPERATURE TRANSMITTER

Local Representation



PO Box 548, 456 Park Ave., Scotch Plains, NJ 07076
Phone: (800) 700-3272 Fax: (800) 700-5468 (US & CA only)
Email: sales@statinst.com Web: www.statinst.com